

# TRANSFORMER PLANTING SPECIFICATIONS

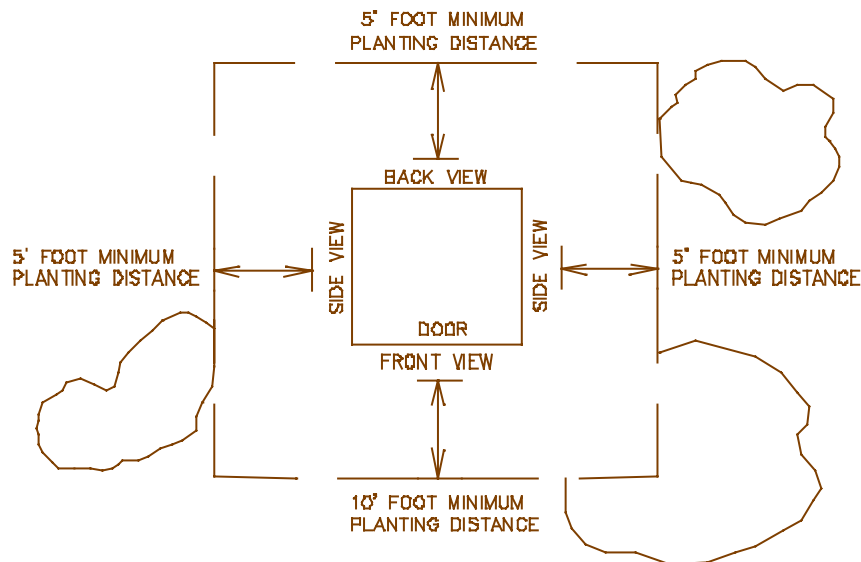
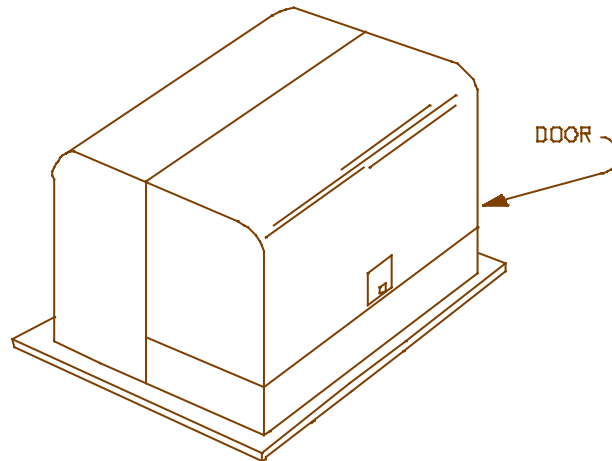

P.E.C.I. TRANSFORMERS COME IN MANY SIZES. THIS IS ONLY ONE EXAMPLE.  
THE SAME PLANTING SCHEME WOULD BE APPROPRIATE FOR ALL TRANSFORMERS.

## NOTE:

1. P.E.C.I. three phase transformer pad dimensions are 74" x 74".
2. Do not install sprinkler systems within watering distance of any electrical equipment.
3. Do not plant shrubbery such as pampas grass, yucca plants, holly or any other pointed plants around this equipment.
4. These minimum planting distances assume plant(s) has reached full maturity.

DATE: April 17, 1997  
APPROVED BY: A. Berl Davis  
REV: \_\_\_\_\_ SHEET 1

MEMO # 19

 **PALMETTO**  
ELECTRIC COOPERATIVE INC.  
A Touchstone Energy<sup>SM</sup> Partner 